

ANNEX 10

**RESOLUTION MEPC.214(63)
Adopted on 2 March 2012**

**2012 GUIDELINES ON SURVEY AND CERTIFICATION OF THE
ENERGY EFFICIENCY DESIGN INDEX (EEDI)**

THE MARINE ENVIRONMENT PROTECTION COMMITTEE,

RECALLING Article 38(a) of the Convention on the International Maritime Organization concerning the functions of the Marine Environment Protection Committee (the Committee) conferred upon it by international conventions for the prevention and control of marine pollution,

RECALLING ALSO that, at its sixty-second session, the Committee adopted, by resolution MEPC.203(62), amendments to the Annex of the Protocol of 1997 to amend the International Convention for the Prevention of Pollution from Ships, 1973, as modified by the Protocol of 1978 relating thereto (inclusion of regulations on energy efficiency for ships in MARPOL Annex VI),

NOTING the amendments to MARPOL Annex VI adopted at its sixty-second session by inclusion of a new chapter 4 for regulations on energy efficiency for ships, are expected to enter into force on 1 January 2013 upon their acceptance on 1 July 2012,

NOTING ALSO that regulation 5 (Surveys) of MARPOL Annex VI, as amended, requires ships to which chapter 4 applies shall also be subject to survey and certification taking into account guidelines developed by the Organization,

RECOGNIZING that the amendments to MARPOL Annex VI requires the adoption of relevant guidelines for smooth and uniform implementation of the regulations and to provide sufficient lead time for industry to prepare,

HAVING CONSIDERED, at its sixty-third session, the draft 2012 Guidelines on survey and certification of the Energy Efficiency Design Index (EEDI),

1. ADOPTS the 2012 Guidelines on survey and certification of the Energy Efficiency Design Index (EEDI), as set out in the annex to the present resolution;
2. INVITES Administrations to take the annexed Guidelines into account when developing and enacting national laws which give force to and implement provisions set forth in regulation 5 of MARPOL Annex VI, as amended;
3. REQUESTS the Parties to MARPOL Annex VI and other Member Governments to bring the annexed Guidelines on survey and certification of the Energy Efficiency Design Index (EEDI), to the attention of masters, seafarers, shipowners, ship operators and any other interested groups;
4. AGREES to keep these Guidelines under review in light of the experience gained; and
5. REVOKES Interim Guidelines circulated by MEPC.1/Circ.682, as from this date.

ANNEX

**2012 GUIDELINES ON SURVEY AND CERTIFICATION OF THE
ENERGY EFFICIENCY DESIGN INDEX (EEDI)**

TABLE OF CONTENTS

1	GENERAL
2	DEFINITIONS
3	APPLICATION
4	PROCEDURES FOR SURVEY AND CERTIFICATION
4.1	General
4.2	Preliminary verification of the attained EEDI at the design stage
4.3	Final verification of the attained EEDI at sea trial
4.4	Verification of the attained EEDI in case of major conversion
Appendix 1	Sample of EEDI Technical File
Appendix 2	Guidelines for validation of electric power tables for EEDI (EPT-EEDI)
Appendix 3	Electric power table form for EEDI (EPT-EEDI Form) and statement of validation

1 GENERAL

The purpose of these Guidelines is to assist verifiers of Energy Efficiency Design Index (EEDI) of ships in conducting the survey and certification of the EEDI in accordance with regulations 5, 6, 7, 8 and 9 of MARPOL Annex VI, and assist shipowners, shipbuilders and manufacturers being related to the energy efficiency of a ship and other interested parties in understanding the procedures of the survey and certification of the EEDI.

2 DEFINITIONS¹

2.1 *Verifier* means an Administration or organization duly authorized by it, which conducts the survey and certification of the EEDI in accordance with regulations 5, 6, 7, 8 and 9 of MARPOL Annex VI and these Guidelines.

2.2 *Ship of the same type* means a ship of which hull form (expressed in the lines such as sheer plan and body plan) excluding additional hull features such as fins and of which principal particulars are identical to that of the base ship.

2.3 *Tank test* means model towing tests, model self-propulsion tests and model propeller open water tests. Numerical calculations may be accepted as equivalent to model propeller open water tests or used to complement the tank tests conducted (e.g. to evaluate the effect of additional hull features such as fins, etc., on ship's performance), with approval of the verifier.

3 APPLICATION

These Guidelines should be applied to new ships for which an application for an initial survey or an additional survey specified in regulation 5 of MARPOL Annex VI has been submitted to a verifier.

4 PROCEDURES FOR SURVEY AND CERTIFICATION

4.1 General

4.1.1 Attained EEDI should be calculated in accordance with regulation 20 of MARPOL Annex VI and the "Guidelines on the method of calculation of the attained EEDI for new ships" ("EEDI Calculation Guidelines", hereafter). Survey and certification of the EEDI should be conducted on two stages: preliminary verification at the design stage, and final verification at the sea trial. The basic flow of the survey and certification process is presented in figure 1.

4.1.2 The information used in the verification process may contain confidential information of submitters, which requires Intellectual Property Rights (IPR) protection. In the case where the submitter want a non-disclosure agreement with the verifier, the additional information should be provided to the verifier upon mutually agreed terms and conditions.

¹ Other terms used in these Guidelines have the same meaning as those defined in the EEDI Calculation Guidelines.

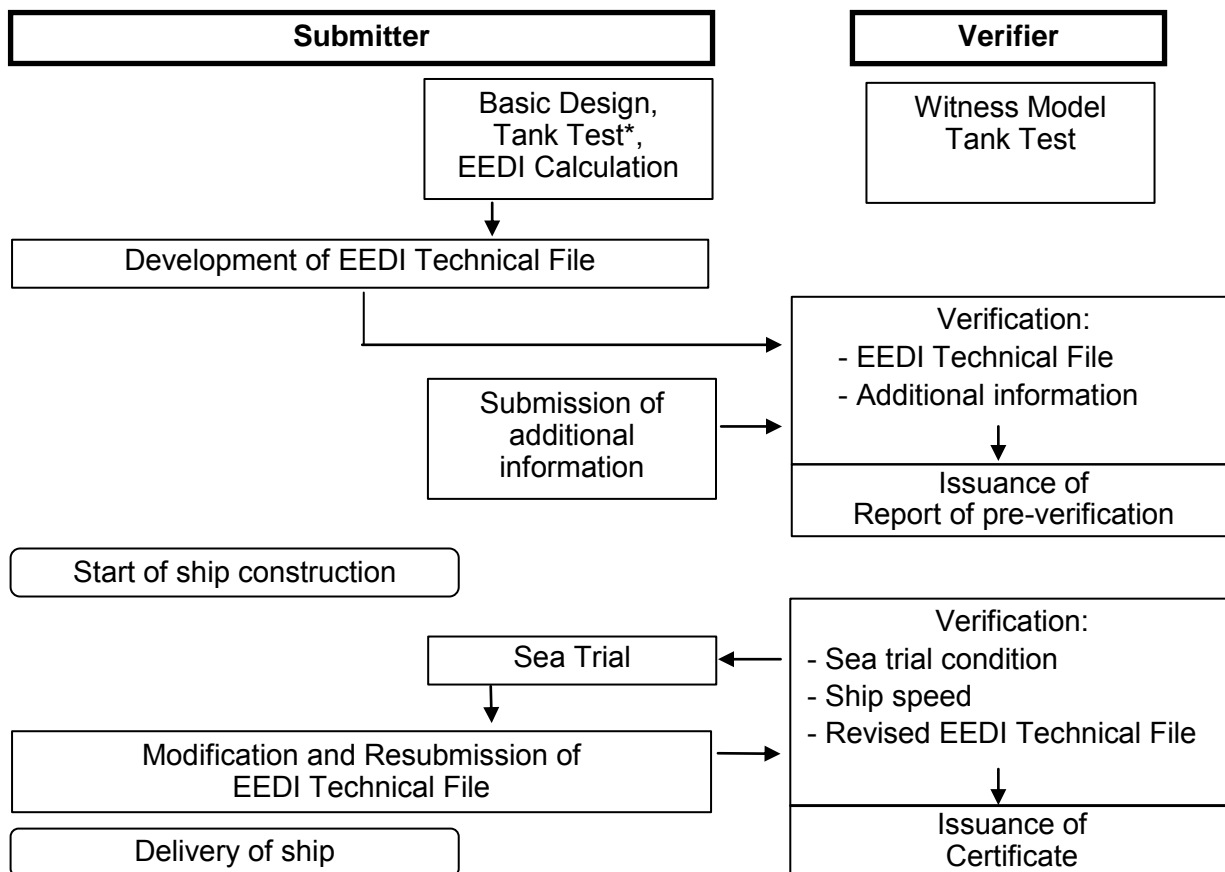

* To be conducted by a test organization or a submitter itself.

Figure 1: Basic Flow of Survey and Certification Process

4.2 Preliminary verification of the attained EEDI at the design stage

4.2.1 For the preliminary verification at the design stage, an application for an initial survey and an EEDI Technical File containing the necessary information for the verification and other relevant background documents should be submitted to a verifier.

4.2.2 EEDI Technical File should be written at least in English. The EEDI Technical File should include at least but not limited to:

- .1 deadweight (DWT) or gross tonnage (GT) for passenger and ro-ro passenger ships, the maximum continuous rating (MCR) of the main and auxiliary engines, the ship speed (V_{ref}), as specified in paragraph 2.2 of the EEDI Calculation Guidelines, type of fuel, the specific fuel consumption (SFC) of the main engine at the 75 per cent of MCR power, the SFC of the auxiliary engines at the 50 per cent MCR power, and the electric power table[†] for certain ship types, as necessary, as defined in the EEDI Calculation Guidelines;
- .2 power curve(s) (kW – knot) estimated at design stage under the condition as specified in paragraph 2.2 of the EEDI Calculation Guidelines, and in the event that the sea trial is carried out in a condition other than the above condition, then also a power curve estimated under the sea trial condition;

- .3 principal particulars, ship type and the relevant information to classify the ship into such a ship type, classification notations and the overview of propulsion system and electricity supply system on board;
- .4 estimation process and methodology of the power curves at design stage;
- .5 description of energy saving equipment;
- .6 calculated value of the attained EEDI including the calculation summary, which should contain, at a minimum, each value of the calculation parameters and the calculation process used to determine the attained EEDI; and
- .7 calculated values of the attained $EEDI_{weather}$ and f_w value (not equal to 1.0), if those values are calculated, based on the EEDI Calculation Guidelines.

† Electric power table should be validated separately, taking into account guidelines set out in appendix 2 to these Guidelines.

A sample of an EEDI Technical File is provided in the appendix 1 to these Guidelines.

4.2.3 If dual fuel engines are installed on the ship, the C_F factor and the Specific Fuel Consumption of gas fuel should be used if gas fuel will be used as the primary fuel on the ship. In order to verify this, the following information should be provided:

- .1 The use of boil-off gas or capacities of the gas fuel storage tanks, and the capacities of fuel oil storage tanks.
- .2 Arrangements of bunkering facilities for gas fuel in the intended operational area of the ship.

4.2.4 The *SFC* of the main and auxiliary engines should be quoted from the approved NO_x Technical File and should be corrected to the value corresponding to the ISO standard reference conditions using the standard lower calorific value of the fuel oil (42,700kJ/kg), referring to ISO 15550:2002 and ISO 3046-1:2002. For the confirmation of the *SFC*, a copy of the approved NO_x Technical File and documented summary of the correction calculations should be submitted to the verifier. In case NO_x Technical File has not been approved at the time of the application for initial survey, the test reports provided by manufacturers should be used. In this case, at the time of the sea trial verification, a copy of the approved NO_x Technical File and documented summary of the correction calculations should be submitted to the verifier.

Note: *SFC* in the NO_x Technical File are the values of a parent engine, and the use of such value of *SFC* for the EEDI calculation for member engines may have the following technical issues for further consideration:

- .1 The definition of "member engines" given in NO_x Technical File is broad and specification of engines belonging to the same group/family may vary; and
- .2 The rate of NO_x emission of the parent engine is the highest in the group/family – i.e. CO_2 emission, which is in the trade-off relationship with NO_x emission, can be lower than the other engines in the group/family.

4.2.5 For ships to which regulation 21 of MARPOL Annex VI applies, the power curves used for the preliminary verification at the design stage should be based on reliable results of tank test. A tank test for an individual ship may be omitted based on technical justifications

such as availability of the results of tank tests for ships of the same type. In addition, omission of tank tests is acceptable for a ship for which sea trials will be carried under the condition as specified in paragraph 2.2 of the EEDI Calculation Guidelines, upon agreement of the shipowner and shipbuilder and with approval of the verifier. For ensuring the quality of tank tests, ITTC quality system should be taken into account. Model tank test should be witnessed by the verifier.

Note: It would be desirable in the future that an organization conducting a tank test be authorized.

4.2.6 The verifier may request the submitter for additional information on top of those contained in Technical File, as necessary, to examine the calculation process of the attained EEDI. The estimation of the ship speed at the design stage much depends on each shipbuilder's experiences, and it may not be practicable for any person/organization other than the shipbuilder to fully examine the technical aspects of experience-based parameters such as the roughness coefficient and wake scaling coefficient. Therefore, the preliminary verification should focus on the calculation process of the attained EEDI to ensure that it is technically sound and reasonable and follows regulation 20 of MARPOL Annex VI and the EEDI Calculation Guidelines.

Note 1: A possible way forward for more robust verification is to establish a standard methodology of deriving the ship speed from the outcomes of tank test, by setting standard values for experience-based correction factors such as roughness coefficient and wake scaling coefficient. In this way, ship-by-ship performance comparison could be made more objectively by excluding the possibility of arbitrary setting of experience-based parameters. If such standardization is sought, this would have an implication on how the ship speed adjustment based on sea trial results should be conducted in accordance with paragraph 4.3.8 of these Guidelines.

Note 2: A joint industry standard to support the method and role of the verifier will be developed.

4.2.7 Additional information that the verifier may request the submitter to provide directly to it includes but not limited to:

- .1 descriptions of a tank test facility; this should include the name of the facility, the particulars of tanks and towing equipment, and the records of calibration of each monitoring equipment;
- .2 lines of a model ship and an actual ship for the verification of the appropriateness of the tank test; the lines (sheer plan, body plan and half-breadth plan) should be detailed enough to demonstrate the similarity between the model ship and the actual ship;
- .3 lightweight of the ship and displacement table for the verification of the deadweight;
- .4 detailed report on the method and results of the tank test; this should include at least the tank test results at sea trial condition and under the condition as specified in paragraph 2.2 of the EEDI Calculation Guidelines;
- .5 detailed calculation process of the ship speed, which should include the estimation basis of experience-based parameters such as roughness coefficient, wake scaling coefficient; and
- .6 reasons for exempting a tank test, if applicable; this should include lines and tank test results of the ships of same type, and the comparison of the

principal particulars of such ships and the ship in question. Appropriate technical justification should be provided explaining why the tank test is unnecessary.

4.2.8 The verifier should issue the report on the "Preliminary Verification of EEDI" after it has verified the attained EEDI at the design stage in accordance with paragraphs 4.1 and 4.2 of these Guidelines.

4.3 Final verification of the attained EEDI at sea trial

4.3.1 Sea trial conditions should be set as conditions specified in paragraph 2.2 of the EEDI Calculation Guidelines, if possible.

4.3.2 Prior to the sea trial, the following documents should be submitted to the verifier: a description of the test procedure to be used for the speed trial, the final displacement table and the measured lightweight, or a copy of the survey report of deadweight, as well as a copy of NO_x Technical File as necessary. The test procedure should include, at a minimum, descriptions of all necessary items to be measured and corresponding measurement methods to be used for developing power curves under the sea trial condition.

4.3.3 The verifier should attend the sea trial and confirm:

- .1 propulsion and power supply system, particulars of the engines, and other relevant items described in the EEDI Technical File;
- .2 draught and trim;
- .3 sea conditions;
- .4 ship speed; and
- .5 shaft power and RPM of the main engine.

4.3.4 Draught and trim should be confirmed by the draught measurements taken prior to the sea trial. The draught and trim should be as close as practical to those at the assumed conditions used for estimating the power curves.

4.3.5 Sea conditions should be measured in accordance with ISO 15016:2002 or the equivalent.

4.3.6 Ship speed should be measured in accordance with ISO 15016:2002 or the equivalent and at more than two points of which range includes the power of the main engine as specified in paragraph 2.5 of the EEDI Calculation Guidelines.

4.3.7 The main engine output should be measured by shaft power meter or a method which the engine manufacturer recommends and the verifier approves. Other methods may be acceptable upon agreement of the shipowner and shipbuilder and with approval of the verifier.

4.3.8 The submitter should develop power curves based on the measured ship speed and the measured output of the main engine at sea trial. For the development of the power curves, the submitter should calibrate the measured ship speed, if necessary, by taking into account the effects of wind, tide, waves, shallow water and displacement in accordance with

ISO 15016:2002² or the equivalent which may be acceptable provided that the concept of the method is transparent for the verifier and publicly available/accessible. Upon agreement with the shipowner, the submitter should submit a report on the speed trials including details of the power curve development to the verifier for verification.

4.3.9 The submitter should compare the power curves obtained as a result of the sea trial and the estimated power curves at the design stage. In case differences are observed, the attained EEDI should be recalculated, as necessary, in accordance with the following:

- .1 for ships for which sea trial is conducted under the condition as specified in paragraph 2.2 of the EEDI Calculation Guidelines: the attained EEDI should be recalculated using the measured ship speed at sea trial at the power of the main engine as specified in paragraph 2.5 of the EEDI Calculation Guidelines; and
- .2 for ships for which sea trial cannot be conducted under the condition as specified in paragraph 2.2 of the EEDI Calculation Guidelines: if the measured ship speed at the power of the main engine as specified in paragraph 2.5 of the EEDI Calculation Guidelines at the sea trial conditions is different from the expected ship speed on the power curve at the corresponding condition, the shipbuilder should recalculate the attained EEDI by adjusting ship speed under the condition as specified in paragraph 2.2 of the EEDI Calculation Guidelines by an appropriate correction method that is agreed by the verifier.

An example of possible methods of the speed adjustment is given in figure 2:

Note: Further consideration would be necessary for speed adjustment methodology in paragraph 4.3.9.2 of these Guidelines. One of the concerns relates to a possible situation where the power curve for sea trial condition is estimated in an excessively conservative manner (i.e. power curve is shifted in a leftward direction) with the intention to get an upward adjustment of the ship speed by making the measured ship speed at sea trial easily exceed the lower-estimated speed for sea trial condition at design stage.

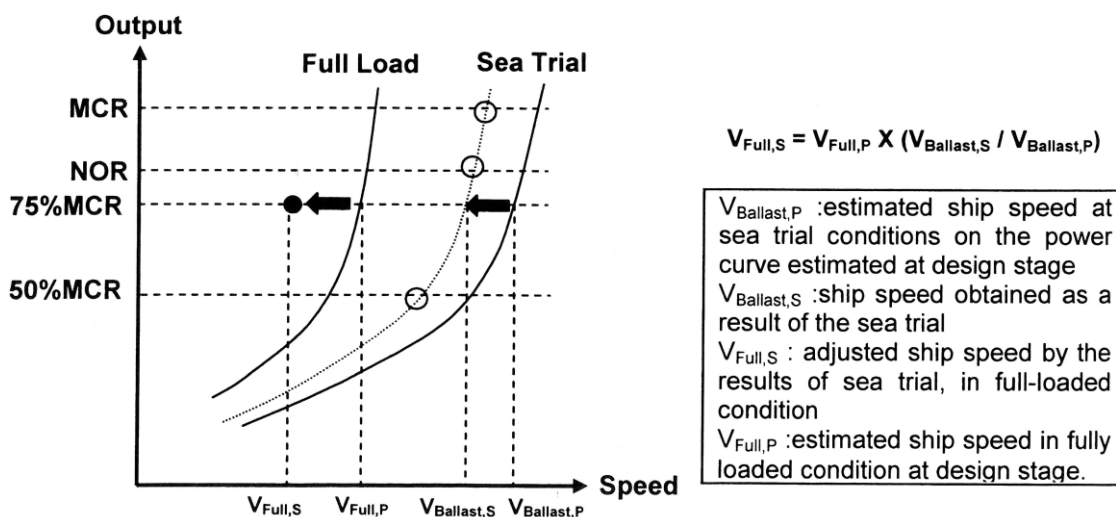

Figure 2: An Example of Possible Ship Speed Adjustment

² An ITTC standard for this purpose will be developed.

4.3.10 In cases where the finally determined deadweight/gross tonnage differs from the designed deadweight/gross tonnage used in the EEDI calculation during the preliminary verification, the submitter should recalculate the attained EEDI using the finally determined deadweight/gross tonnage. The finally determined gross tonnage should be confirmed in the Tonnage Certificate of the ship.

4.3.11 In case where the attained EEDI is calculated at the preliminary verification by using *SFC* based on the manufacturer's test report due to the non-availability at that time of the approved NO_x Technical File, the EEDI should be recalculated by using *SFC* in the approved NO_x Technical File.

4.3.12 The EEDI Technical File should be revised, as necessary, by taking into account the results of sea trial. Such revision should include, as applicable, the adjusted power curve based on the results of sea trial (namely, modified ship speed under the condition as specified in paragraph 2.2 of the EEDI Calculation Guidelines), the finally determined deadweight/gross tonnage and *SFC* described in the approved NO_x Technical File, and the recalculated attained EEDI based on these modifications.

4.3.13 The EEDI Technical File, if revised, should be submitted to the verifier for the confirmation that the (revised) attained EEDI is calculated in accordance with regulation 20 of MARPOL Annex VI and the EEDI Calculation Guidelines.

4.4 Verification of the attained EEDI in case of major conversion

4.4.1 In cases where a major conversion is made to a ship, the shipowner should submit to a verifier an application for an Additional Survey with the EEDI Technical File duly revised based on the conversion made and other relevant background documents.

4.4.2 The background documents should include at least but are not limited to:

- .1 documents explaining details of the conversion;
- .2 EEDI parameters changed after the conversion and the technical justifications for each respective parameter;
- .3 reasons for other changes made in the EEDI Technical File, if any; and
- .4 calculated value of the attained EEDI with the calculation summary, which should contain, at a minimum, each value of the calculation parameters and the calculation process used to determine the attained EEDI after the conversion.

4.4.3 The verifier should review the revised EEDI Technical File and other documents submitted and verify the calculation process of the attained EEDI to ensure that it is technically sound and reasonable and follows regulation 20 of MARPOL Annex VI and the EEDI Calculation Guidelines.

4.4.4 For verification of the attained EEDI after a conversion, speed trials of the ship are required, as necessary.

APPENDIX 1

SAMPLE OF EEDI TECHNICAL FILE

1 Data

1.1 General information

Shipbuilder	JAPAN Shipbuilding Company
Hull No.	12345
IMO No.	94111XX
Kind of ship	Bulk carrier

1.2 Principal particulars

Length overall	250.0 m
Length between perpendiculars	240.0 m
Breadth, moulded	40.0 m
Depth, moulded	20.0 m
Summer load line draught, moulded	14.0 m
Deadweight at summer load line draught	150,000 tons

1.3 Main engine

Manufacturer	JAPAN Heavy Industries Ltd.
Type	6J70A
Maximum continuous rating (MCR)	15,000 kW x 80 rpm
SFC at 75% MCR	165.0 g/kWh
Number of set	1
Fuel type	Diesel Oil

1.4 Auxiliary engine

Manufacturer	JAPAN Diesel Ltd.
Type	5J-200
Maximum continuous rating (MCR)	600 kW x 900 rpm
SFC at 50% MCR	220.0 g/kWh
Number of set	3
Fuel type	Diesel Oil

1.5 Ship speed

Ship speed in deep water at summer load line draught at 75% of MCR	14.25 knots
--	-------------

2 Power Curves

The power curves estimated at the design stage and modified after the speed trials are shown in figure 2.1.

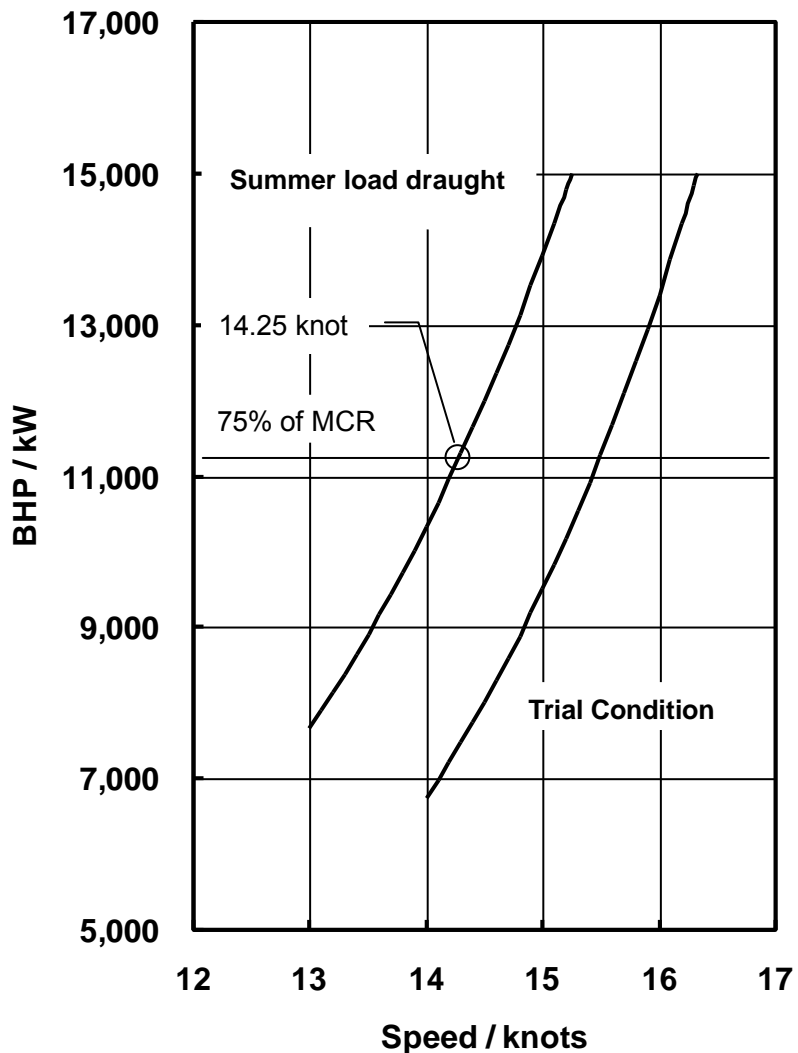

Figure 2.1: Power curves

3 Overview of Propulsion System and Electric Power Supply System

3.1 Propulsion system

3.1.1 Main engine

Refer to subparagraph 1.3.

3.1.2 Propeller

Type	Fixed pitch propeller
Diameter	7.0 m
Number of blades	4
Number of set	1

3.2 Electric power supply system

3.2.1 Auxiliary engines

Refer to subparagraph 1.4.

3.2.2 Main generators

Manufacturer	JAPAN Electric
Rated output	560 kW (700 kVA) x 900 rpm
Voltage	AC 450 V
Number of set	3

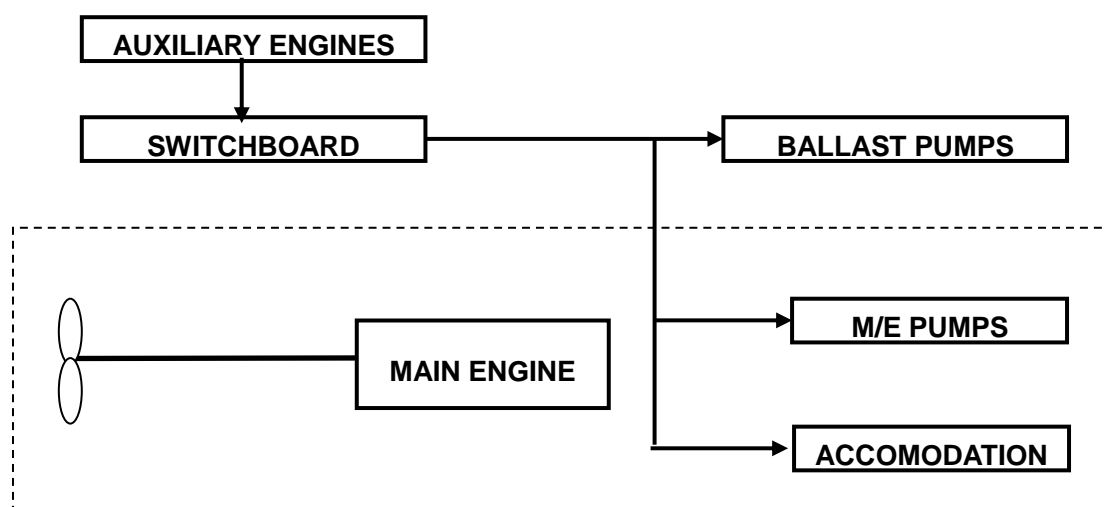

Figure 3.1: Schematic figure of propulsion and electric power supply system

4 Estimation Process of Power Curves at Design Stage

Power curves are estimated based on model test results. The flow of the estimation process is shown below.

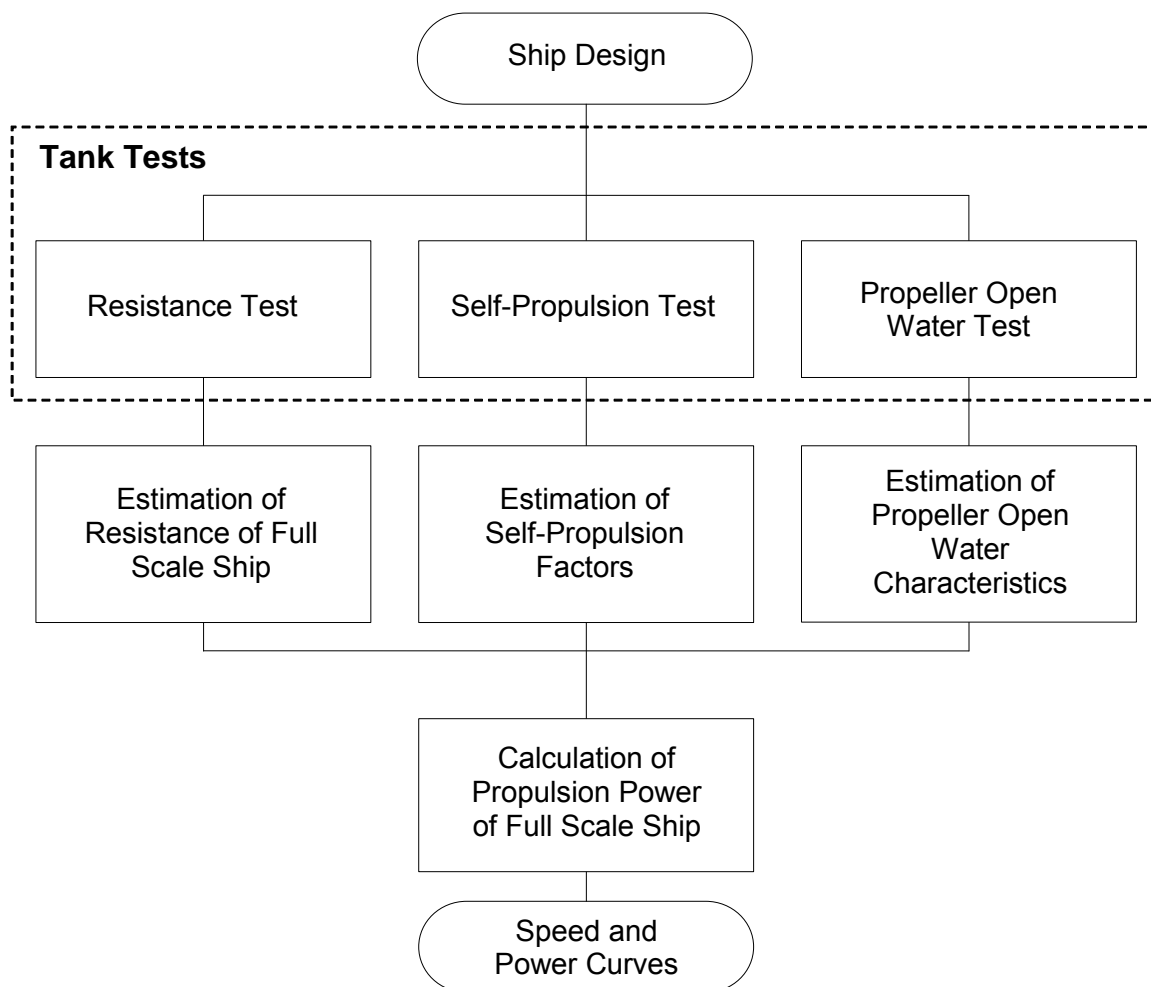

Figure 4.1: Flow-chart of process for estimating power curves

5 Description of Energy Saving Equipment

5.1 Energy saving equipment of which effects are expressed as $P_{AEff(i)}$ and/or $P_{eff(i)}$ in the EEDI calculation formula

N/A

5.2 Other energy saving equipment

(Example)

5.2.1 Rudder fins

5.2.2 Propeller boss cap fins

.....

(Specifications, schematic figures and/or photos, etc., for each piece of equipment or device should be indicated. Alternatively, attachment of the commercial catalogue may be acceptable.)

6 Calculated Value of attained EEDI

6.1 Basic data

Type of Ship	Capacity DWT	Speed V_{ref} (knots)
Bulk Carrier	150,000	14.25

6.2 Main engine

MCR_{ME} (kW)	Shaft Gen.	P_{ME} (kW)	Type of Fuel	C_{FME}	SFC_{ME} (g/kWh)
15,000	N/A	11,250	Diesel Oil	3.206	165.0

6.3 Auxiliary engines

P_{AE} (kW)	Type of Fuel	C_{FAE}	SFC_{AE} (g/kWh)
625	Diesel Oil	3.206	220.0

6.4 Ice class

N/A

6.5 Innovative electrical energy efficient technology

N/A

6.6 Innovative mechanical energy efficient technology

N/A

6.7 Cubic capacity correction factor

N/A

6.8 Calculated value of attained EEDI

$$\begin{aligned}
 EEDI &= \frac{\left(\prod_{j=1}^M f_j \right) \left(\sum_{i=1}^{nME} P_{ME(i)} \cdot C_{FME(i)} \cdot SFC_{ME(i)} \right) + (P_{AE} \cdot C_{FAE} \cdot SFC_{AE})}{f_i \cdot f_c \cdot Capacity \cdot f_w \cdot V_{ref}} \\
 &+ \frac{\left\{ \left(\prod_{j=1}^M f_j \cdot \sum_{i=1}^{nPTE} P_{PTE(i)} - \sum_{i=1}^{neff} f_{eff(i)} \cdot P_{AE_{eff(i)}} \right) C_{FAE} \cdot SFC_{AE} \right\} - \left(\sum_{i=1}^{neff} f_{eff(i)} \cdot P_{eff(i)} \cdot C_{FME} \cdot SFC_{ME} \right)}{f_i \cdot f_c \cdot Capacity \cdot f_w \cdot V_{ref}} \\
 &= \frac{1 \times (11250 \times 3.206 \times 165.0) + (625 \times 3.206 \times 220.0) + 0 - 0}{1 \cdot 1 \cdot 150000 \cdot 1 \cdot 14.25} \\
 &= 2.99 \text{ (g - CO}_2\text{/ton \cdot mile)}
 \end{aligned}$$

attained EEDI: 2.99 g-CO₂/ton mile

7 Calculated value of attained EEDI_{weather}

7.1 Representative sea conditions

	Mean wind speed	Mean wind direction	Significant wave height	Mean wave period	Mean wave direction
BF6	12.6 (m/s)	0 (deg.)*	3.0 (m)	6.7 (s)	0 (deg.)*

* Heading direction of wind/wave in relation to the ship's heading, i.e. 0 (deg.) means the ship is heading directly into the wind.

7.2 Calculated weather factor, f_w

f_w	0.900
-------	-------

7.3 Calculated value of attained EEDI_{weather}

attained EEDI_{weather}: 3.32 g-CO₂/ton mile

APPENDIX 2

GUIDELINES FOR VALIDATION OF ELECTRIC POWER TABLES FOR EEDI (EPT-EEDI)

1 INTRODUCTION

The purpose of these Guidelines is to assist Recognized Organizations in the validation of ship's Electric Power Tables (EPT) for calculation of Energy Efficiency Design Index (EEDI). As such, these Guidelines support the implementation of "GUIDELINES ON THE METHOD OF CALCULATION OF THE ATTAINED ENERGY EFFICIENCY DESIGN INDEX FOR NEW SHIPS" ("EEDI Calculation Guidelines", hereafter) and "GUIDELINES ON SURVEY AND CERTIFICATION OF THE ENERGY EFFICIENCY DESIGN INDEX". This document will also assist shipowners, shipbuilders, ship designers, and manufacturers in relation to aspects of developing more energy efficient ships and also in understanding the procedures for the EPT-EEDI validation.

2 OBJECTIVES

These Guidelines provide a framework for the uniform application of the EPT-EEDI validation process for those ships that come under paragraph 2.5.6.3 of the EEDI Calculation Guidelines.

3 DEFINITIONS

3.1 *Applicant* means an organization, primarily a shipbuilder or a ship designer, which requests the EPT-EEDI validation in accordance with these Guidelines.

3.2 *Validator* means a Recognized Organization which conducts the EPT-EEDI validation in accordance with these Guidelines.

3.3 *Validation* for the purpose of these Guidelines means review of submitted documents and survey during construction and sea trials.

3.4 *Standard EPT-EEDI-Form* refers to the layout given in appendix 3 that contains the EPT-EEDI results that will be the subject of validation. Other supporting documents submitted for this purpose will be used as reference only and will not be subject to validation.

3.5 P_{AE} herein is defined as per definition in paragraph 2.5.6 of the EEDI Calculation Guidelines.

3.6 *Ship Service and Engine-room Loads* refer to all the load groups which are needed for the hull, deck, navigation and safety services, propulsion and auxiliary engine services, engine-room ventilation and auxiliaries and ship's general services.

3.7 *Diversity Factor* is the ratio of the "total installed load power" and the "actual load power" for continuous loads and intermittent loads. This factor is equivalent to the product of service factors for load, duty and time.

4 APPLICATION

4.1 These Guidelines are applicable to ships as stipulated by paragraph 2.5.6.3 of the EEDI Calculation Guidelines.

4.2 These Guidelines should be applied for new ships for which an application for an EPT-EEDI validation has been submitted to a validator.

4.3 The steps of the validation process include:

- .1 Review of documents during the design stage
 - .1.1 Check if all relevant loads are listed in the EPT;
 - .1.2 Check if reasonable service factors are used; and
 - .1.3 Check the correctness of the P_{AE} calculation based on the data given in the EPT.
- .2 Survey of installed systems and components during construction stage
 - .2.1 Check if a randomly selected set of installed systems and components are correctly listed with their characteristics in the EPT.
- .3 Survey of sea trials
 - .3.1 Check if selected units/loads specified in EPT are observed.

5 SUPPORTING DOCUMENTS

5.1 The applicant should provide as a minimum the ship electric balance load analysis.

5.2 Such information may contain shipbuilders' confidential information. Therefore, after the validation, the validator should return all or part of such information to the applicant at the applicant's request.

5.3 A special EEDI condition during sea trials may be needed and defined for each vessel and included into the sea trial schedule. For this condition a special column should be inserted into the EPT.

6 PROCEDURES FOR VALIDATION

6.1 General

6.1.1 P_{AE} should be calculated in accordance with the EPT-EEDI Calculation Guidelines. EPT-EEDI validation should be conducted in two stages: preliminary validation at the design stage and final validation during sea trials. The validation process is presented in figure 1.

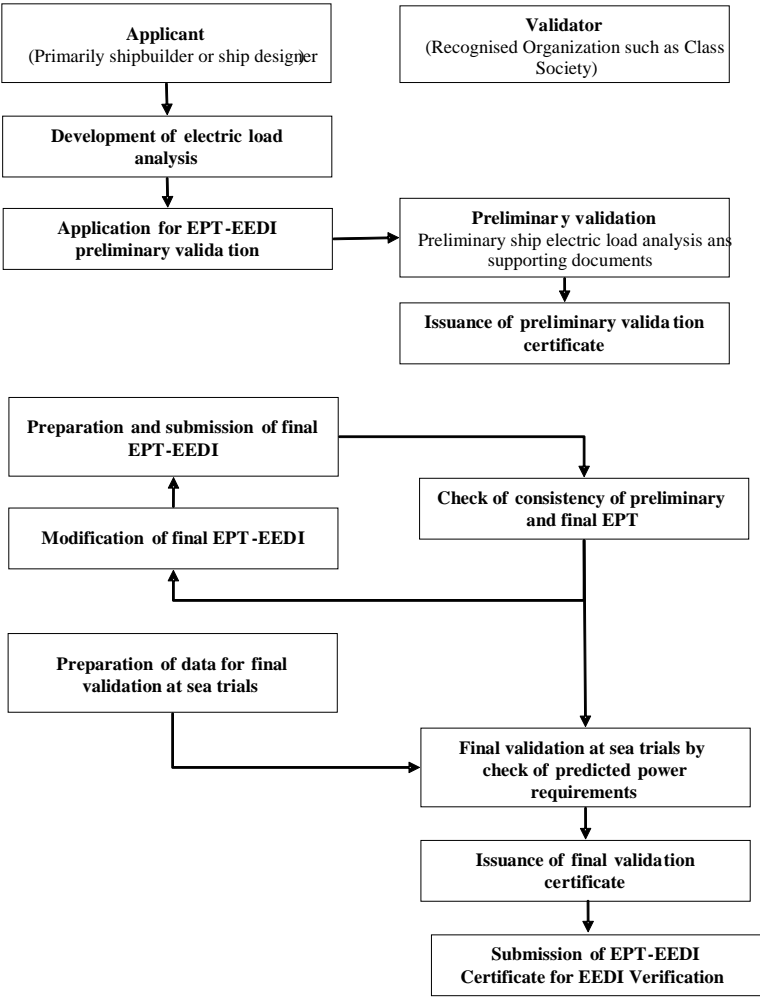

Figure 1: Basic Flow of EPT-EEDI Validation Process

6.2 Preliminary validation at the design stage

6.2.1 For the preliminary validation at the design stage, the applicant should submit to a validator an application for the validation of EPT-EEDI inclusive of EPT-EEDI Form and all the relevant and necessary information for the validation as supporting documents.

6.2.2 The applicant should supply as a minimum the supporting data and information, as specified in appendix A (to be developed).

6.2.3 The validator may request from the applicant additional information on top of those contained in these Guidelines, as necessary, to enable the validator to examine the calculation process of the EPT-EEDI. The estimation of the ship EPT-EEDI at the design stage depends on each applicant's experiences, and it may not be practicable to fully examine the technical aspects and details of each machinery component. Therefore, the preliminary validation should focus on the calculation process of the EPT-EEDI that should follow the best marine practices.

Note: A possible way forward for more robust validation is to establish a standard methodology of deriving the ship EPT by setting standard formats as agreed and used by industry.

6.3 Final validation

6.3.1 The final validation process as a minimum shall include the check of ship electric load analysis to ensure that all electric consumers are listed; their specific data and the calculations in the power table itself are correct and are supported by sea trial results. If necessary, additional information has to be requested.

6.3.2 For final validation the applicant shall revise the EPT-EEDI Form and supporting documents as necessary, by taking into account the characteristics of the machinery and other electrical loads actually installed on board the ship. The EEDI condition at sea trials shall be defined and the expected power requirements in these conditions documented in the EPT. Any changes within the EPT from design stage to construction stage should be highlighted by the shipyard.

6.3.3 The preparation for the final validation includes a desk top check comprising:

- .1 consistency of preliminary and final EPT;
- .2 changes of service factors (compared to the preliminary validation);
- .3 all electric consumers are listed;
- .4 their specific data and the calculations in the power table itself are correct; and
- .5 in case of doubt, component specification data is checked in addition.

6.3.4 A survey prior to sea trials is performed to ensure that machinery characteristics and data as well as other electric loads comply with those recorded in the supporting documents. This survey does not cover the complete installation but selects randomly a number [to be defined] of samples.

6.3.5 For the purpose of sea trial validation, the surveyor will check the data of selected systems and/or components given in the special column added to the EPT for this purpose or the predicted overall value of electric load by means of practicable measurements with the installed measurement devices.

7 ISSUANCE OF THE EPT-EEDI STATEMENT OF VALIDATION

7.1 The validator should stamp the EPT-EEDI Form "as Noted" after it validated the EPT-EEDI in the preliminary validation stage in accordance with these Guidelines.

7.2 The validator should stamp the EPT-EEDI Form "as Endorsed" after it validated the final EPT-EEDI in the final validation stage in accordance with these Guidelines.

APPENDIX 3

**ELECTRIC POWER TABLE FORM FOR ENERGY EFFICIENCY DESIGN INDEX
(EPT-EEDI FORM) AND STATEMENT OF VALIDATION**

Ship ID:

IMO No.: _____
Ship's Name: _____
Shipyard: _____
Hull No.:5 Miles _____

Applicant:

Name: _____
Address: _____

Validation Stage:

Preliminary validation
 Final validation

Summary Results of EPT-EEDI

Load Group	Seagoing Condition EEDI Calculation Guidelines		Remarks
	Continuous Load (kW)	Intermittent Load (kW)	
Ship Service and Engine-room Loads			
Accommodation and Cargo Loads			
Total installed load			
Diversity Factor			
Normal seagoing load			
Weighted average efficiency of generators			
PAE			

Supporting Documents

Title	ID or Remarks

Validator details:

Organization: _____
Address: _____

This is to certify that the above-mentioned electrical loads and supporting documents have been reviewed in accordance with EPT-EEDI Validation Guidelines and the review shows a reasonable confidence for use of the above PAE in EEDI calculations.

The date of review: _____ Statement of validation No. _____

This statement is valid on condition that the electric power characteristics of the ship do not change.

Signature of Validator

Printed Name:
